

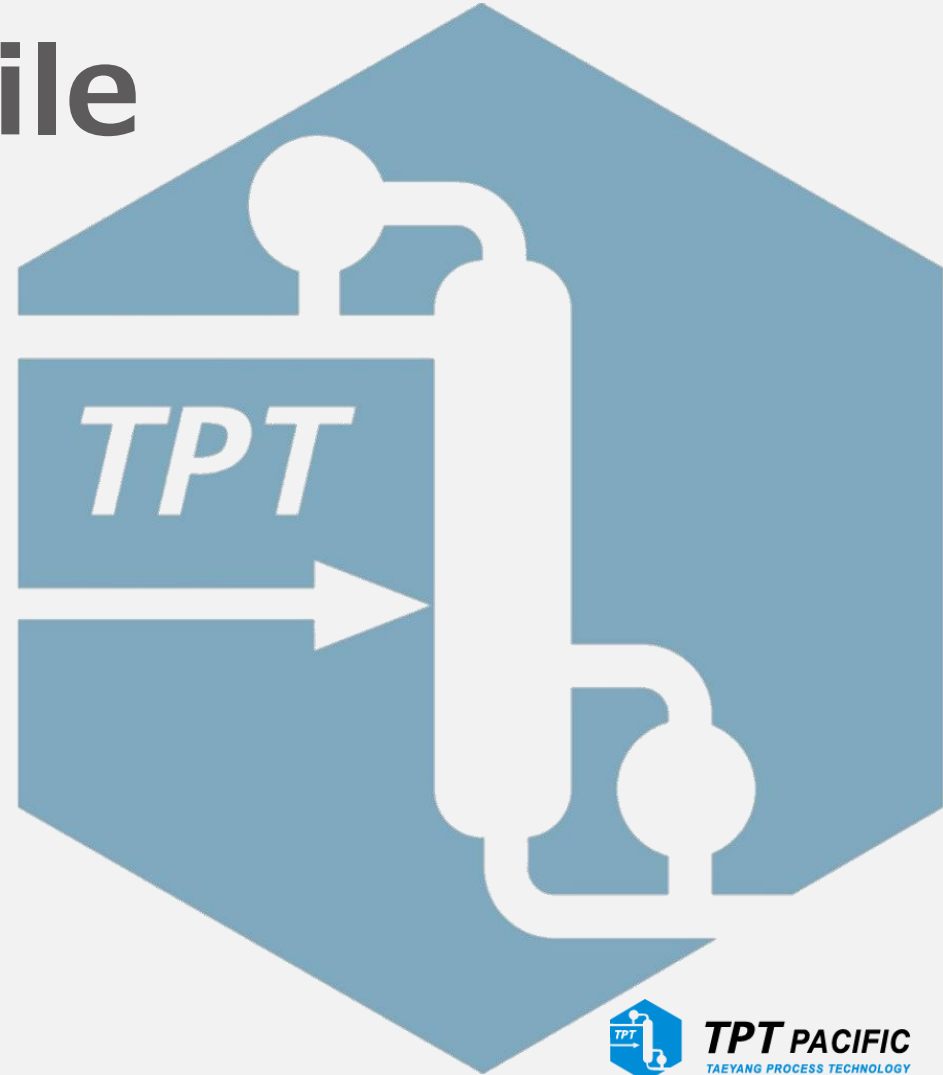

# TPT Pacific Company Profile



**TPT PACIFIC**  
TAEYANG PROCESS TECHNOLOGY



# • Contents

1. Introduction
2. Business Fields
3. Main Products
4. Revamping
5. Column Scanning
6. Major Experiences
7. Product Delivered Locations
8. Process Design Technologies
9. R&D

# 1. Introduction

## (Company Profile)

**TPT Pacific(TPT)** has been established in Oct. 2000 under the name of AMT Pacific Co., Ltd. by the experienced engineers came out from SK Engineering & Construction Ltd., who used to work in the field of Mass Transfer Business such as design and fabrication of Tower Internals like tray & packing.

The leading personnel of TPT Pacific have been conducting the successful business in Mass Transfer Equipments, Distillation System Design and Process Basic Engineering since 1989.



---

# 1. Introduction

## (History Summary)

**1989**

Masstransfer Business team in SK E&C has made the License agreement with Glitsch USA.

**1997**

Glitsch has been merged by the Competitor. Major engineers came out from Glitsch to establish AMT International in USA. SK E&C and AMT Int'l have entered into an Agreement.

**2000**

Engineers from SK E&C came out to establish AMT Pacific in Korea. AMT Pacific and AMT Int'l have signed the Agreement .

**2003**

AMT Pacific has built its own factory in Ulsan Korea.

**2013**

AMT Int'l has been merged by Beijing Zehua.

**2015**

Agreement between AMT Pacific and AMT Int'l is closed. AMT Pacific changed its name to **TPT Pacific**.

# 1. Introduction

## (Key member's profile)

The key engineers and fabrication leaders with 18~25 years of experiences in TPT Pacific have been working not only for the mass transfer equipments, but for revamping and process basic engineering for the distillation unit of the oil & gas, petrochemical, and chemical plants.

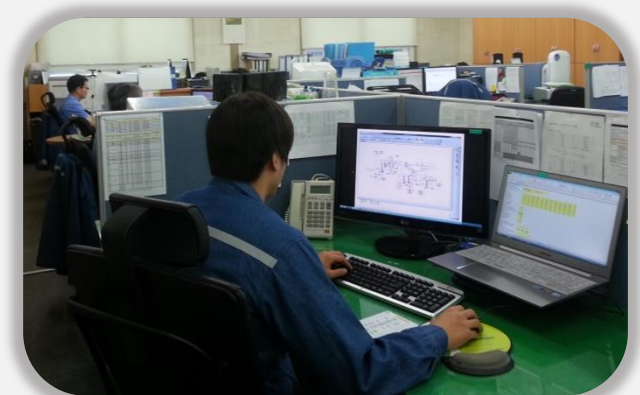

# 1.1 History Summary

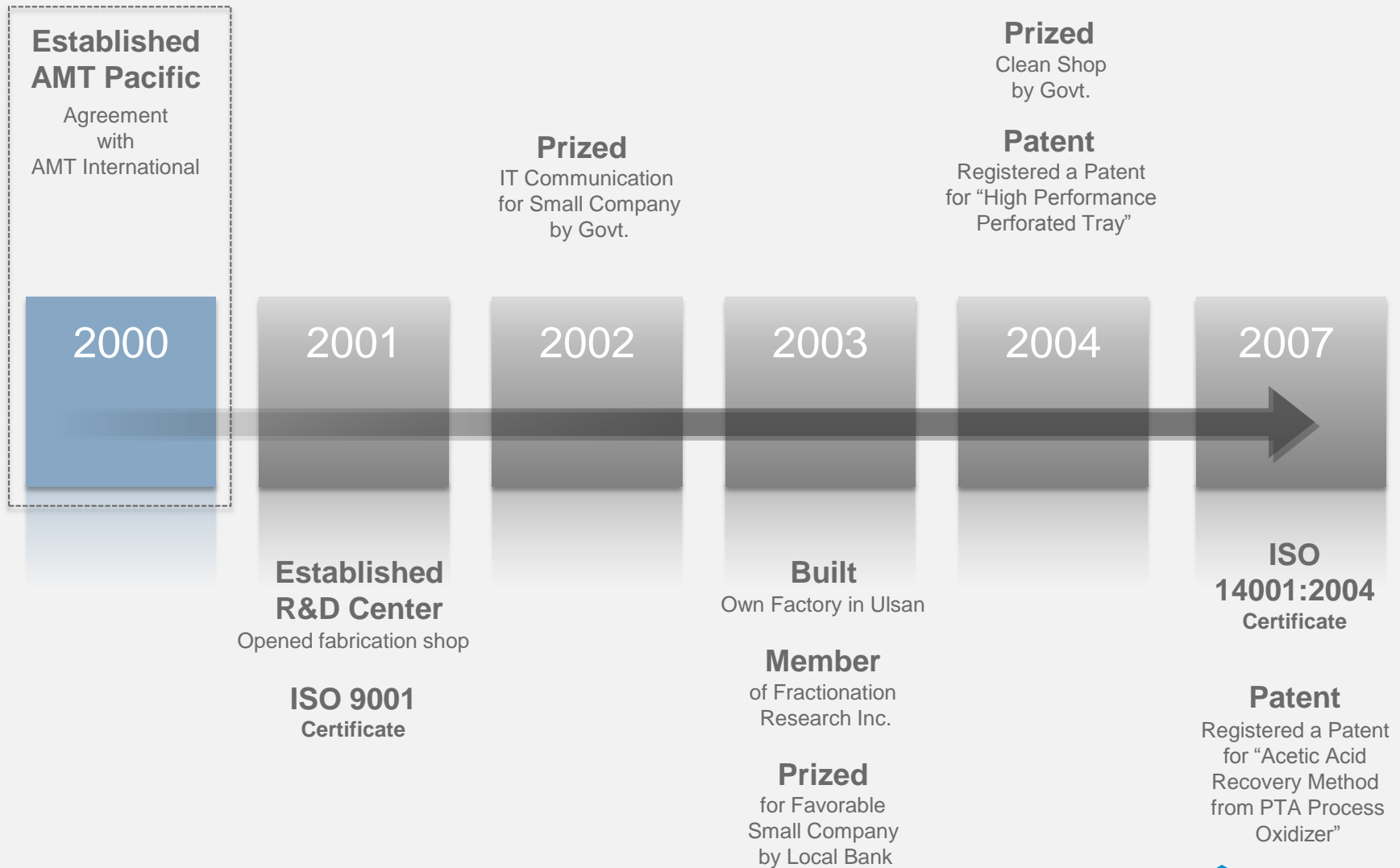

# 1.1 History Summary



# 1.2 Organization Chart



# 2. Business Fields

## - Mass Transfer Technology

### Oil & Gas Petrochemical

Process innovation  
Optimum solutions  
Cost effective design

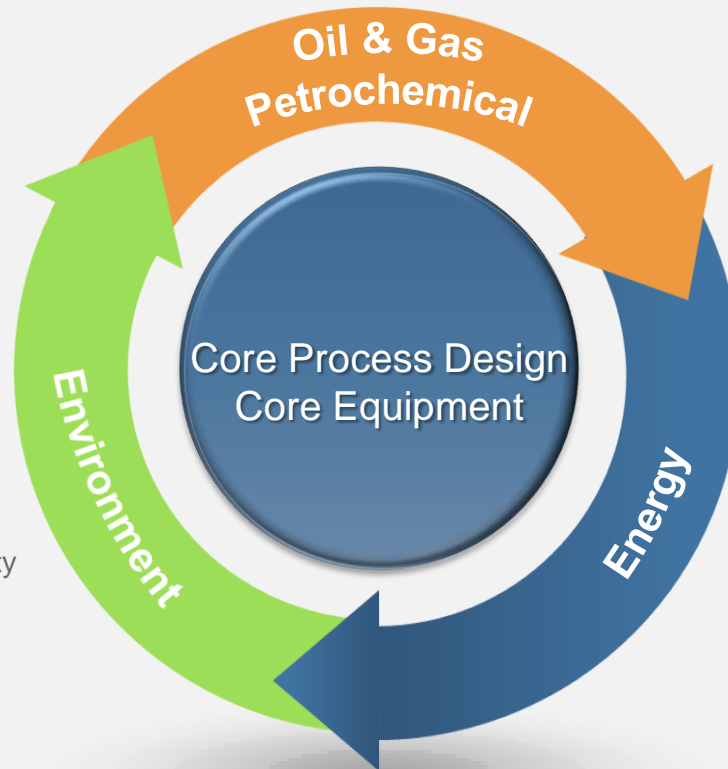

### Environment

Environmental responsibility

### Energy

Energy-efficient solutions



**TPT PACIFIC**  
TAEYANG PROCESS TECHNOLOGY

# 3. Main Products

## - Fractionation Trays



**Fractionation Tray**

- Conventional Valve Tray (TCV, TRV, TCVE, etc.)
- Fixed Valve Tray
- Sieve Tray
- Dual Flow Tray
- Bubble Cap Tray



**High Performance Tray**

- TDV , TCMV Tray, etc.



**Other Tray**

- Disc & Donut Tray
- Side to Side Tray (Baffle Tray)
- Liquid to Liquid Tray

# 3. Main Products

## - Packings



**Structured Packing**

- TSP-64 X/Y, 85, 90, 125, 175, 200, 220, 250, 300, 350, 450, 500, 750, 1000, etc.
- Available in metal (sheet & wire gauze), plastic and ceramic



**Random Packing**

- TP-Ring, TC-Ring, TI-Ring, etc.
- Available in metal, plastic and ceramic

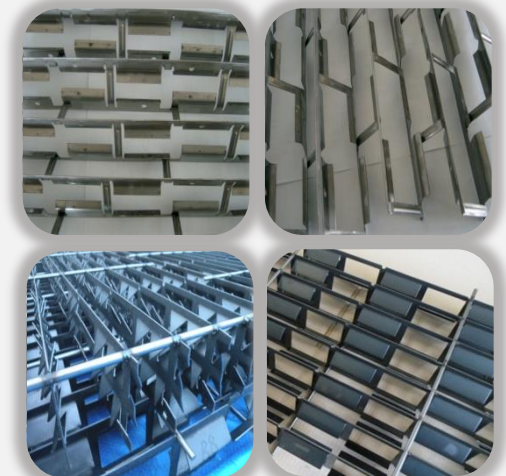

**Grid Packing**

- TGP-1,2,3,4
- TGP-F2, F3
- Available in metal



# 3. Main Products

## - Packed Tower Internals

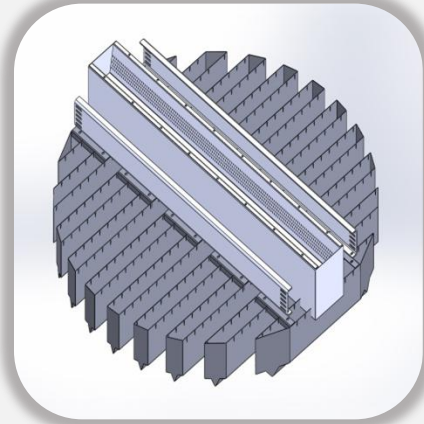

**Liquid distributor**

- Trough Type Distributor
- Riser Orifice Pan Type Distributor
- Pipe Ladder Type Distributor
- Spray Nozzle Distributor



**Bed Limiter**

- Bed Limiter
- Hold Down Grid

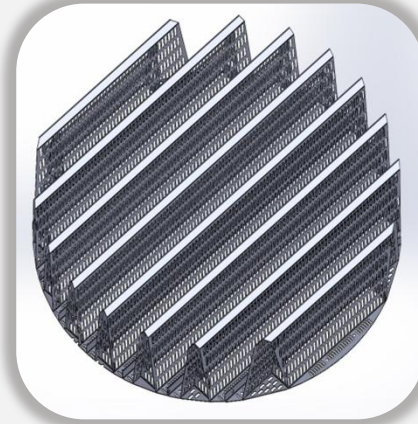

**Packing Support**

- Gas Injection Type Packing Support
- Grid Type Packing Support

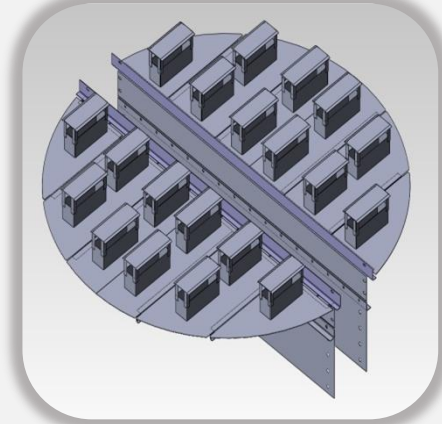

**Collector Tray**

- Riser Type Collector Tray
- Chevron Type Collector Tray



# 4. Revamping

## Objectives

- Increase capacity
- Improve purity
- Energy saving
- Reduce pressure drop
- Chemical recovery and/or pollution control
- Reduce fouling and/or clogging trouble

## Type of Revamping

- Replace trays with high performance trays
- Replace trays with packing
- Replace packing with high performance trays
- Optimize existing tower internals
- Optimize the overall separation system



# 4.1 Revamping Case 1

## - Isomer column

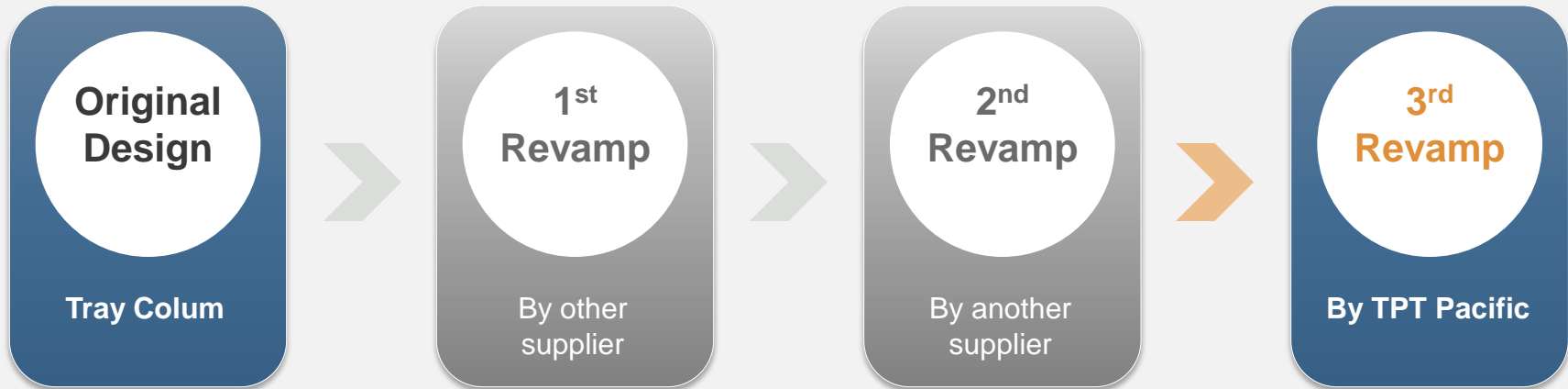

### Revamp target

Increase capacity & improve purity



### 1<sup>st</sup> Revamp

Trays to structured packing (lost separation performance)



### 2<sup>nd</sup> Revamp

Structured packing type change & increase bed height (performance turned to be worse)



# 4.1 Revamping Case 1

## - After revamp (by TPT Pacific)

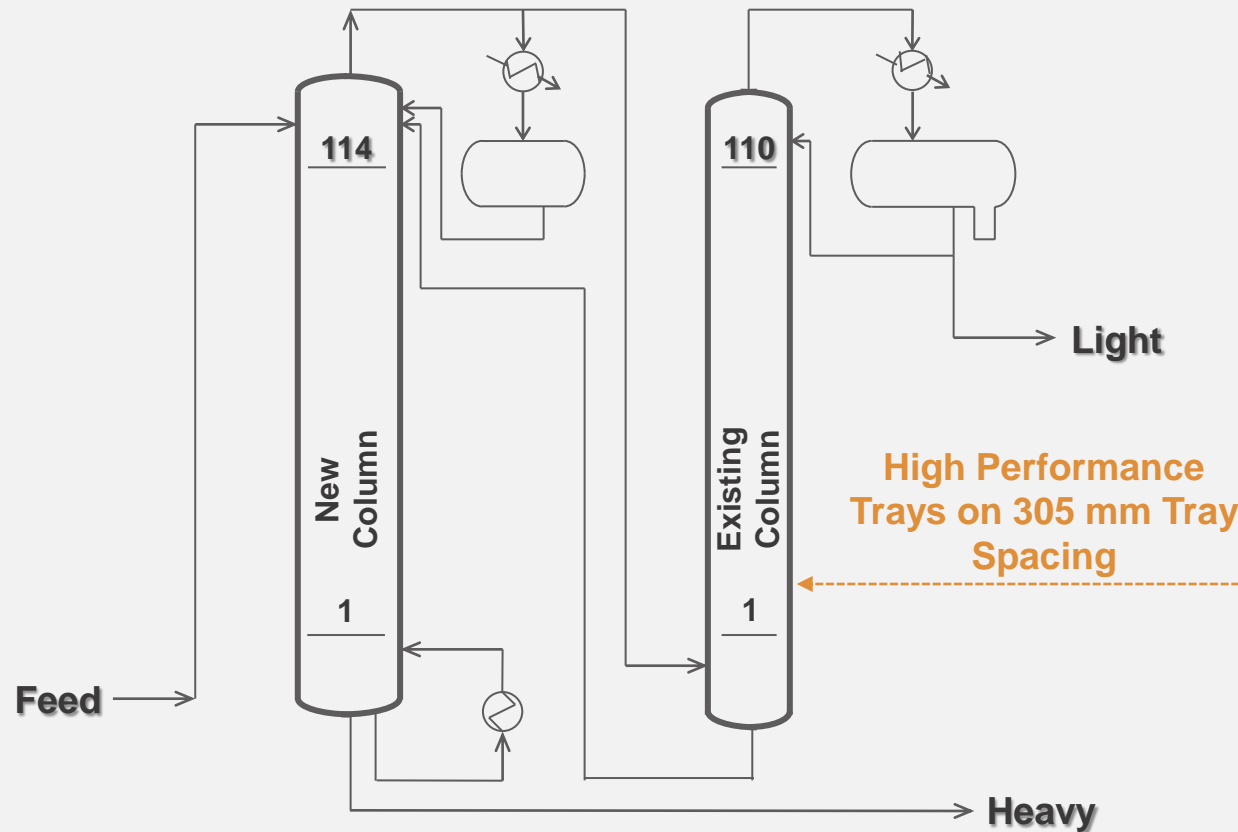

# 4.1 Revamping Case 1

## - Performance summary

Case	Before Revamp	Design Basis (Max)	After Revamp
No. of Trays	110 / SP	110 / 114	110 / 114
No. of Pass	2	2 / 2	2 / 2
Tray Spacing (mm)	305	305	305
Tray Type	Valve & Structured Packing	High Performance Tray / High Performance Tray	High Performance Tray / High Performance Tray
Feed Rate (%)	100	107.5	112.5
<b>Product Purities (wt%)</b>			
Heavy, Overhead	0.73	0.01	< 10 ppm
Light, Bottom	0.06	0.01	45 ~ 60 ppm
Tray Efficiency (%)	58	74.5	80

# 4.2 Revamping Case 2

## - Main fractionator (Refinery)

Background	Revamp Objective
LGO Color(3.0 ASTM D1500)	LGO Color → Max. 2.0
HGO Color(over 8.0 ASTM D1500)	

TPT Pacific proposed to optimize the tray design in Wash oil section, LGO/HGO fractionation section.

# 4.2 Revamping Case 2

- Solutions for revamp by TPT Pacific & Performance result after revamp

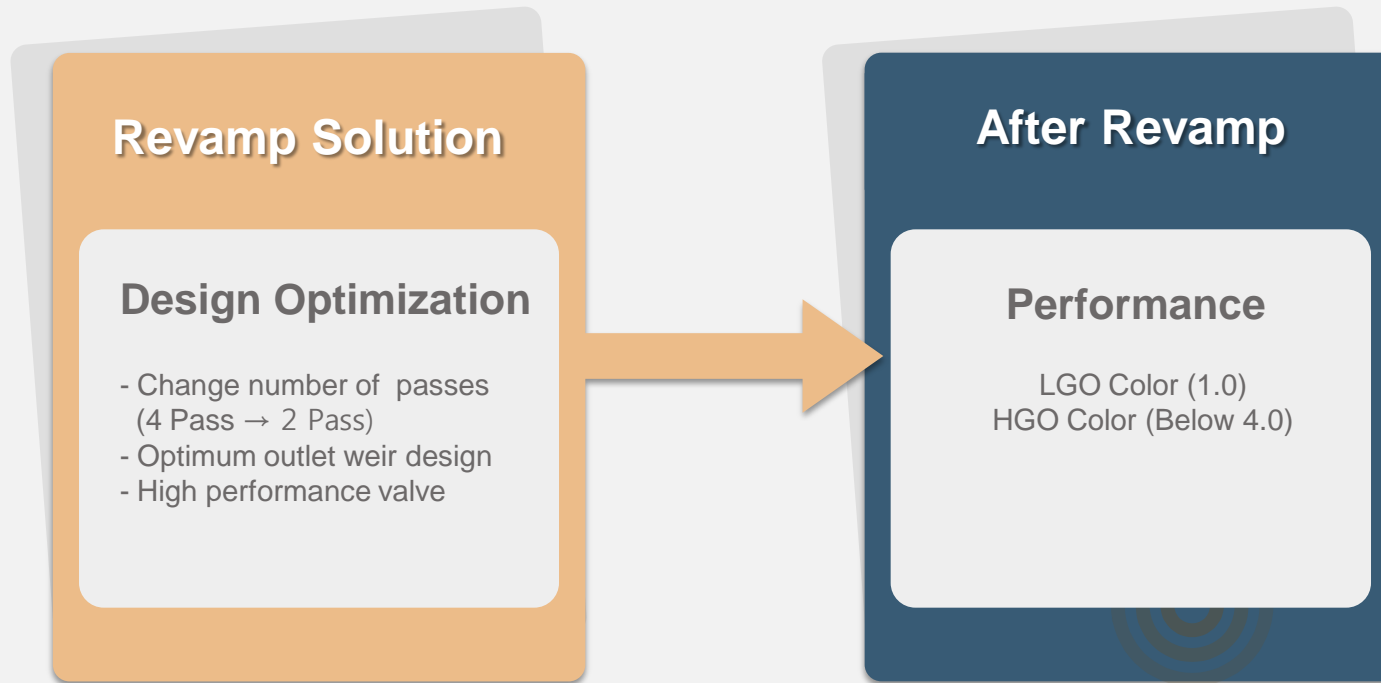

# 4.3 Revamping Case 3

## - HP absorber(PTA Plant)

	PLANT A			PLANT B		
Condition	Existing internal	Water Spray	HoAC in Vent Gas	Existing internal	Water spray	HoAC in vent gas
Before revamp	High performance tray	1200 (kg/hr)	5~10 (ppm wt.)	Random & structured packing	4500 (kg/hr)	60 ~80 (ppm wt.)
After revamp	Structured packing	700 (kg/hr)	N.D.	Structured packing	2500 (kg/hr)	N.D.

# 5. Column Scanning

## Gamma Ray Scanning

Scan the column during operation  
 Outside the insulation  
 Using computer controlled apparatus

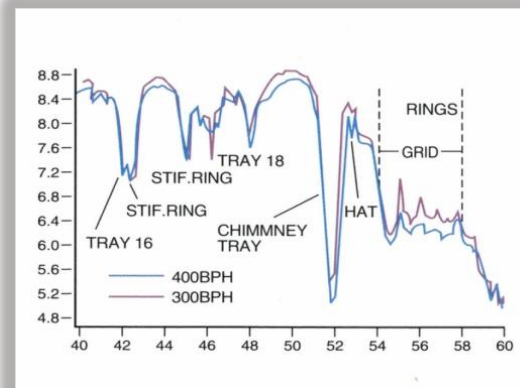
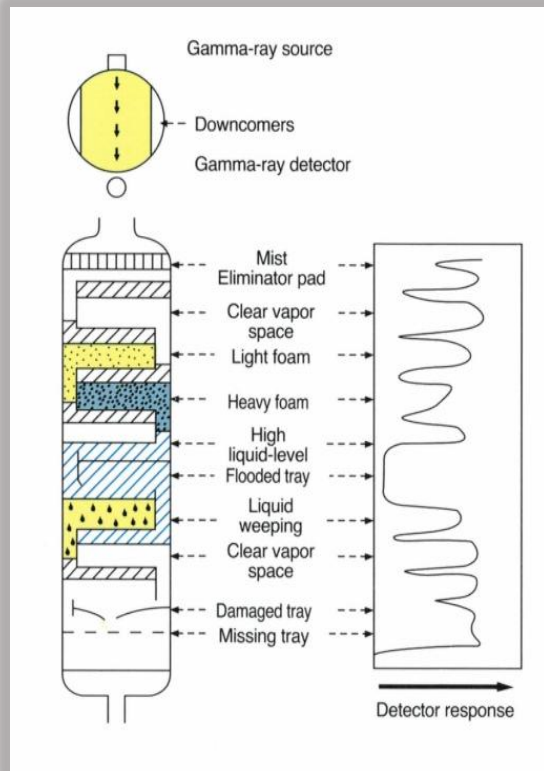
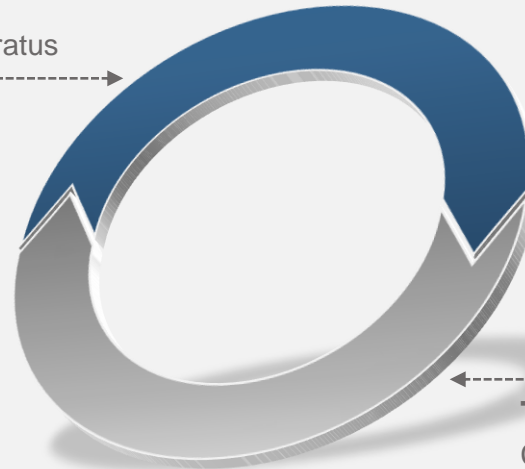

### To Verify

Collapsed internals  
 Fouling and/or clogging  
 Flooding / severe weeping  
 Uneven distribution

### To Prepare

Required internals and/or works  
 prior to shutdown

<Diagrams from Gamma-ray Scanning>

# 6. Major Experiences

<b>Refinery</b>	CDU / VDU	NCC	FCC
	HOU	HDS	LBO
	LPG	-	-
<b>Petrochemical / Chemical Plant</b>	PTA	Acetic Acid	BPA
	AN	AA	Oxo-Alchole
	NPG	EB / SM	MMA
	VAM	DMT	BTX / BD
<b>Etc.</b>	Poly Silicon	CCS	Water Recovery
	FPSO	Ripple Tray	-

## <Major Client>

KNPC, TAKREER, BASF, Amoco Mitsui Indonesia, Technip S&W, PTTGC, SK Innovation, GS Caltex, S-OIL, Hyundai Oil Bank, Lotte Chemicals, SK Chemicals, SK Petrochemicals, SKC, LG Chemicals, LG MMA, Kumho Mitsui, Kumho Petrochemicals, Hyundai Chemicals, Samsung SDI, Samsung Fine Chemicals, Samsung BP, Hanwha Total, Hanwha Chemicals, Hyosung, OCI, Solvay, SK E&C, Samsung Eng'g, GS E&C, Daelim Industrial, Hyundai E&C, Hyundai Eng'g, POSCO Eng'g, Daewoo E&C, etc.



# 7. Product Delivered Locations



## Location

Korea, Japan, China, Taiwan, Thailand, Indonesia, Saudi Arabia, Kuwait, Qatar, UAE, Turkey, Iran, Pakistan, France, Romania, USA, Mexico, Nigeria, Uzbekistan, etc.



**TPT PACIFIC**  
TAEYANG PROCESS TECHNOLOGY

# 8. Process Design Technologies

## 8.1 Mass transfer process basic engineering

- BTX Sulfolane Extraction
- Butadien Extractive Distillation
- LPG Extraction (Amine)
- Acetic Acid Purification Unit
- PTA Acetic Acid dehydration Azeotropic Distillation
- Vinyl Acetate Monomer Distillation
- LPG Recovery Distillation Unit
- Acrylic Acid Distillation Unit
- NPG (Neo Pentyl Glycol) Distillation
- 2EH (2-Ethyl Hexanol) Distillation
- EB/SM Distillation
- TDI, TDA Distillation
- MDI, MDA Distillation
- Acrylonitrile Distillation
- NCC Quench Column
- Butylaldehyde Isomer Splitter
- Aniline Extraction
- Acid Gas Absorption, Regeneration System (NH<sub>3</sub>) (Amine)
- Crude Distillation Column

### **Other Petrochemical, Chemical, Finechemical**

: Azeotropic, Extractive, Reactive Distillation, Extraction



---

# 8. Process Design Technologies

## 8.2 Acid gas removal process basic engineering

- Sulfinol Process (Petrochemical)
- Rectisol Process (Petrochemical)
- MDEA Process (Refinery, NCC, Petrochemical)
- DEA Process (FCC)
- MEA Process (Petrochemical)
- Benfield Process (Petrochemical)
- Ammonia (Steel Company)
- LPG-Amine Extraction (FCC)

# 8. Process Design Technologies

## 8.3 Divided wall column design

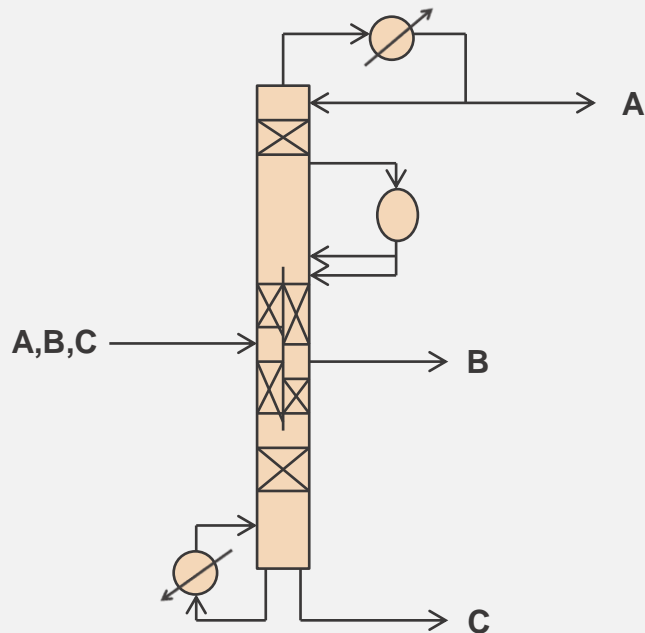

Column	Energy saving (%)
N-BuOH Recovery Column	45 %
Oxo-alcohol Column	20 %
NPG Product Column	15 %
Biodiesel Column	\$1 Million / Year
IPA Column	15 %
VAM Column	Capa. enhancing Investment cost saving

### What TPT Pacific does?

- DWC modeling & simulation
- Optimum DWC design
- High performance DWC internal design & supply
- Column modification & internal installation consulting
- Liquid Splitter design & supply

# 8. Process Design Technologies

## 8.3 Divided wall column design

(Patent for “Non-moving Liquid Splitter”)

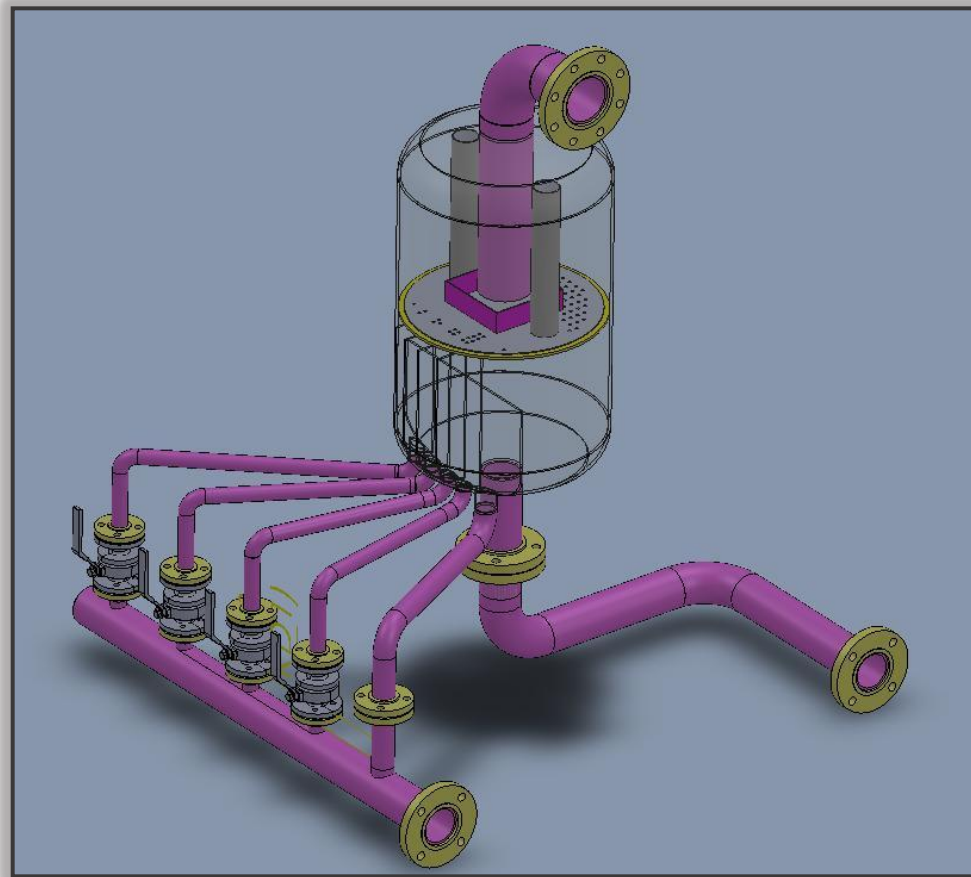

# 8. Process Design Technologies

## 8.4 Forward osmosis (Ammonium carbonate) semi-permeable membrane + distillation

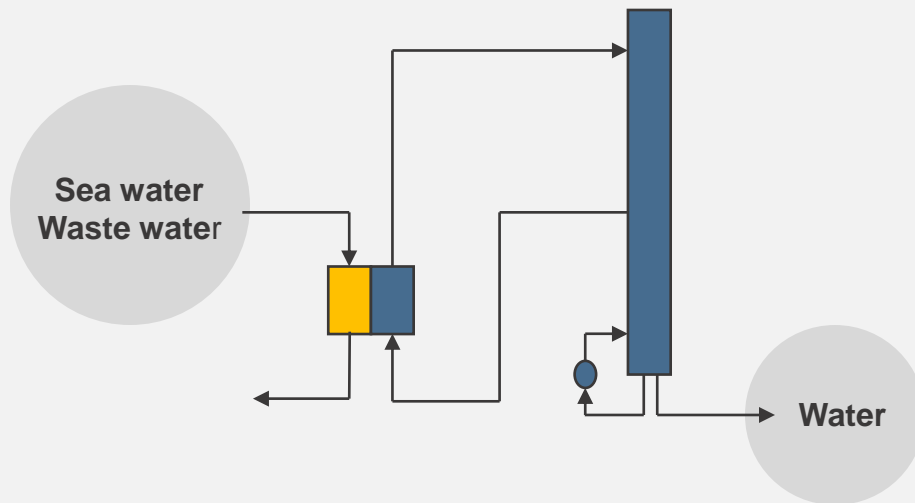

### - Desalination

3.5% NaCl, 100 Ton/hr → 7.0% NaCl, 50 ton/hr  
; Water Product 50 ton/hr,  
Steam consumption 10 ton/hr,  
0.2 ton-steam/ton-water,  
20 kg-CO<sub>2</sub>/ton-water,  
Chiller 2.5 MMkcal/hr, 20~25C

### - Waste water treatment

0.2% HoAc, 100 Ton/hr → 2% HoAc, 10 ton/hr  
; Water Product 90 ton/hr,  
Steam consumption 20 ton/hr,  
0.22 ton-steam/ton-water,  
23 kg-CO<sub>2</sub>/ton-water,  
Chiller 5.0 MMkcal/hr, 20~25C

# 9. Research & Developments



DISTILLATION SYSTEM

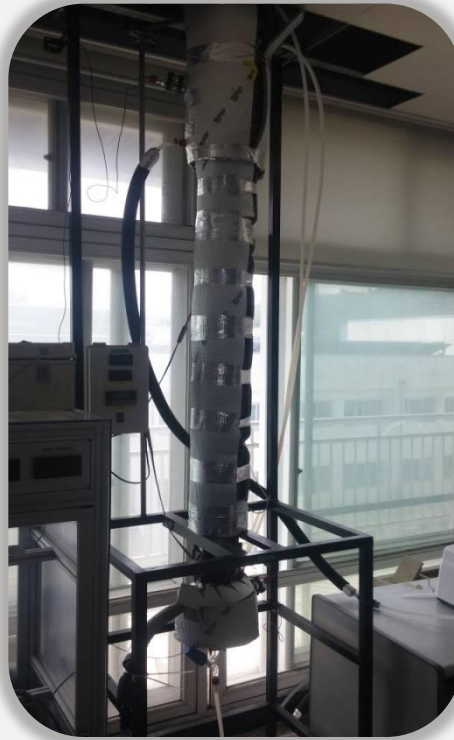

EXTRACTOR SYSTEM



SHORT PATH DISTILLATION

# 9. Research & Developments

## 9.1 Developments

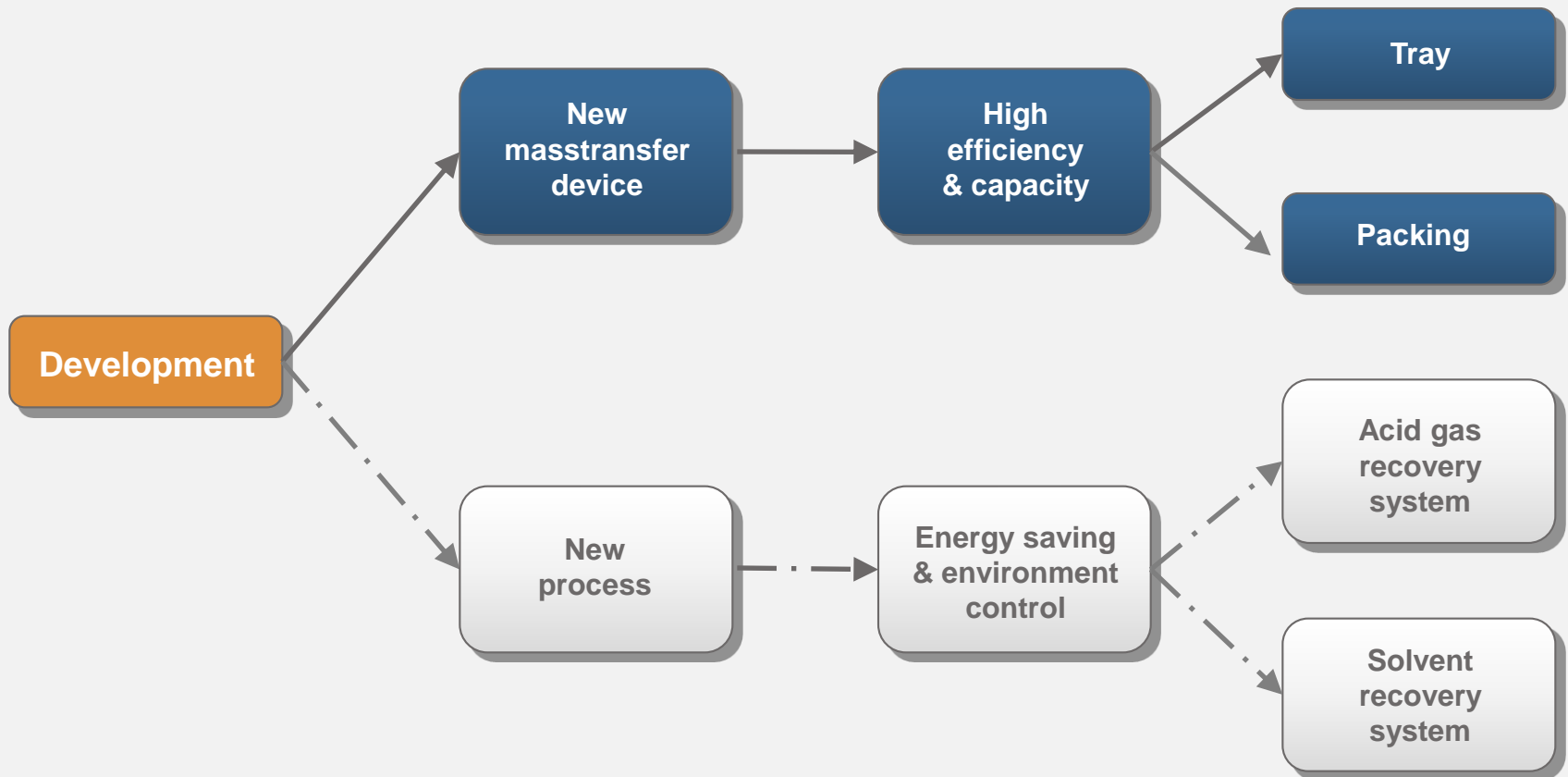

# 9. Research & Developments

## 9.2 R&D History (1/2)

Grid Packing

Structured  
Packing

Trough type  
Liquid Distributor

Fixed Valve( 1)  
Streamline shaped  
Valve (1)

Vapor / Liquid  
Contacting  
Device

High Capacity  
Dual Flow Tray

Liquid Splitter for  
DWC (3)

**\* 10 Patents for masstransfer device since 2001**



# 9. Research & Developments

## 9.2 R&D History (2/2)

- Reducing method of water from reactor outlet gas in the oxidation process of Aromatic compound
- Apparatus for recovering CO<sub>2</sub> from flue gas using NH<sub>3</sub> solution
- Recovering method of acetic acid from the effluent of manufacturing of aromatic carboxylic acid by energy contributing distillation.
- Apparatus and method regenerating ammonium carbonate draw solution from forward osmosis semi-permeable membrane process
- Recovering method of acetic acid from reactor emission in the oxidation process of aromatic compound
- Phase separation absorbent composition for removing acid gas and removing method of acid gas
- Method for recovering acetic acid in preparing aromatic carboxylic acid

**\* 7 Patents for process**

---

# 9. Research & Developments

## 9.3 Softwares for R&D and engineering

- **Simulation program for process development**

  - PRO-II (Simsci, USA)

  - Aspen plus (Aspen Tech, USA)

- **Hydraulic program for mass transfer device development**

  - TPT Program

  - FRI Program

- **Mechanical engineering softwares**

  - STAAD PRO

  - AUTO CAD

  - SOLID WORKS

- **Computational fluid dynamics(CFD) : Out-sourcing**



---

# 9. Research & Developments

## 9.4 Governmental R&D projects

- Energy saving divided wall column design

TPT Pacific, LG R&D CENTER, YOUNGNAM UNIVERSITY

- CO2 capturing

TPT Pacific, KIER

TPT Pacific, RIST, POSCO

TPT Pacific, KEPRI, Daelim Industrial, POSCO Engineering

- FPSO(Floating production storage and offloading)

TPT Pacific, GS E&C

TPT Pacific, Samsung Heavy Industry

- Water recovery

TPT Pacific, KIMM(Korea Institute of Machinery & Materials)

# 9. Research & Development

## 9.5 Test facility for mass transfer devices

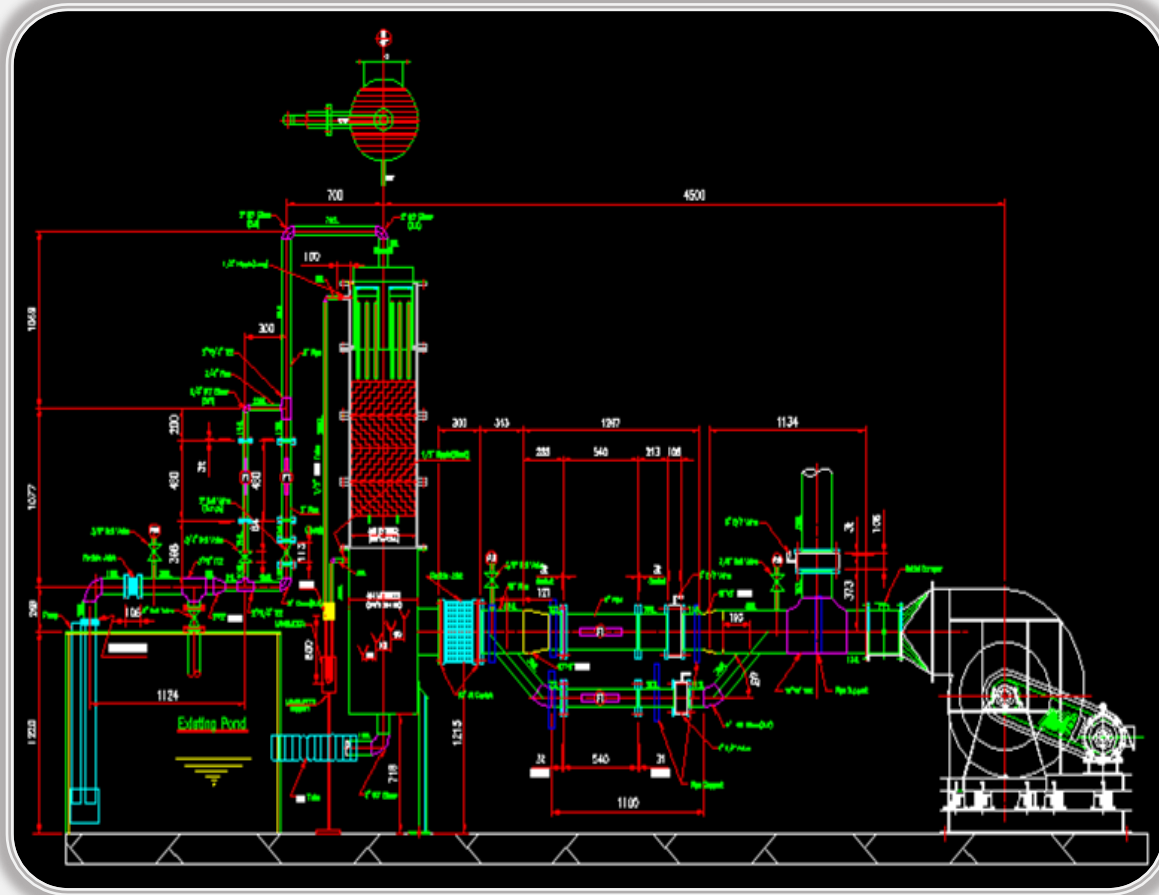

- Location : TPT Pacific, Ulsan, Korea
- Area : 100 M2

# 9. Research & Development

## 9.6 Laboratory for new process developments

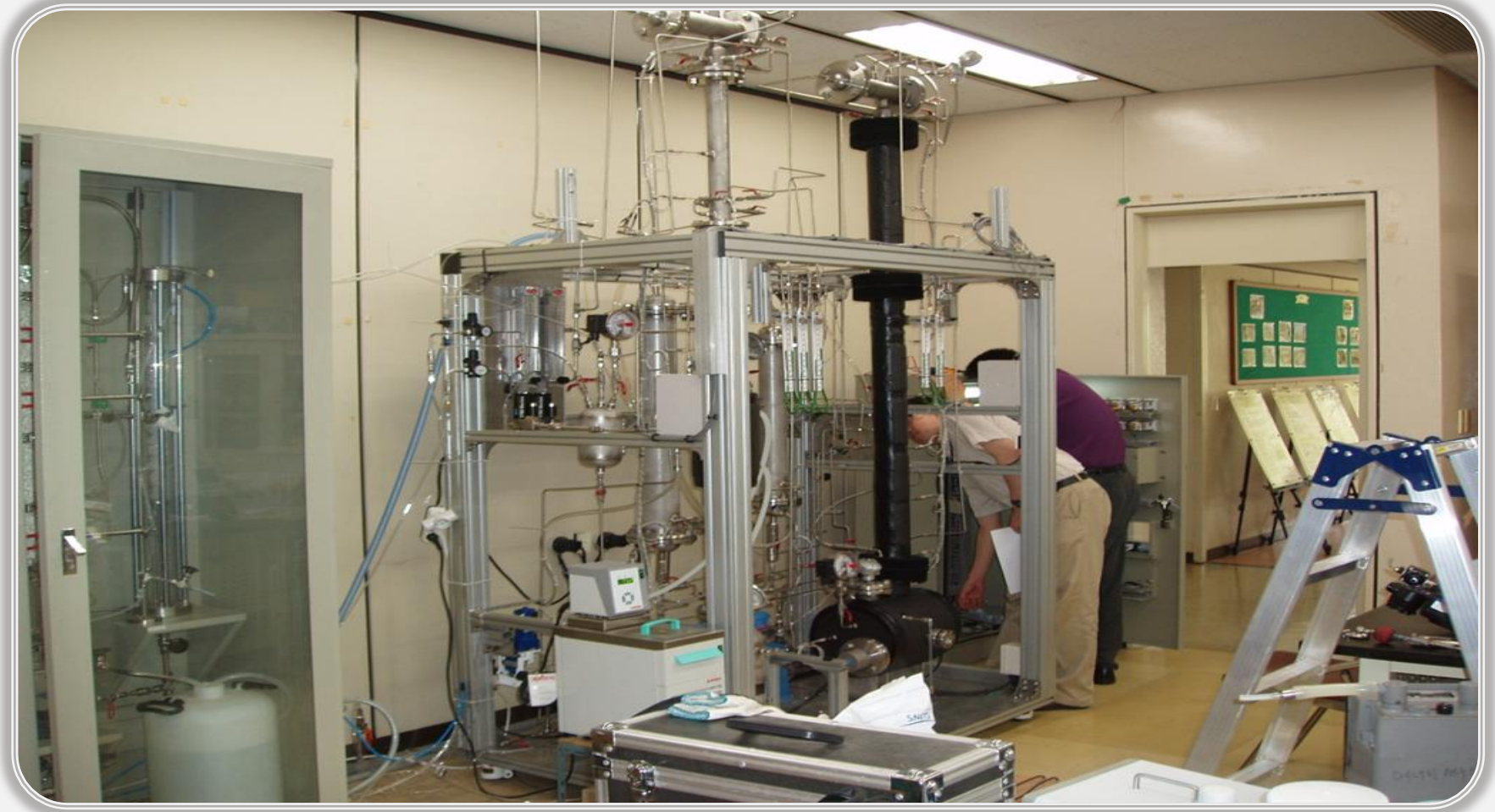

- Location : Room #418, 3<sup>rd</sup> B/D of KIER, Daejeon, Korea

- Area : 61 M2



**TPT PACIFIC**  
TAEYANG PROCESS TECHNOLOGY

# 9. Research & Developments

## 9.7 Ulsan factory



- Land : 6,400 M2
- Building : 2,800 M2

---

# Thank You

## -The end-

### Head Office

1st Floor, Hanaro B/D, 25, Insadong 5-gil, Jongno-gu, Seoul, 03162, Korea  
Tel) +82-2-6356-2550 Fax) +82-2-6356-2565

### Factory

19, Sannam-gil, Onsan-eup, Ulju-gun, Ulsan, 45010, Korea  
Tel) +82-52-237-2720 Fax) +82-52-237-2721

### Homepage & E-mail

[www.ttpacific.com](http://www.ttpacific.com)  
[tpt@ttpacific.com](mailto:tpt@ttpacific.com)



**TPT PACIFIC**  
TAEYANG PROCESS TECHNOLOGY

---